

DATA SHEET

REF. BC2

AUTOSANITIZER PROANPLUS



GENERAL

WARRANTY: 2 years.
BATTERIES DURATION: 14 months (Alkaline LR20 x 2).
ACTUATION METHOD: Mechanical system.
ACTUATION MODE: Programming for 30 or 60 days and turn on the switch.

AMBIENCE

TEMPERATURE RANGE: 5 / 45°C.
HUMIDITY RANGE: 20-90%.

AUTOSANITIZER PROANPLUS

MOUNTING: Screwed to the wall or with adhesive.
NET WEIGHT: 552g.
GROSS WEIGHT: 653g.
DIMENSIONS: 230 x 120 x 90mm / 9,05 x 4,72 x 3,54inch.
MATERIAL: ABS and Polypropylene.
COLOR: White / Black.
SAFETY LOCK: Integrated.
MARKETING: Can be customized with logo / label.

ELECTRONICS

VOLTAGE: 1,5 V.
SENSOR: LED flashes at 0,22 sec. intervals.

REFILL

CAPACITY: 600ml.
CHARACTERISTICS: Rigid. Plastic packaging.
MATERIAL: Polypropylene.
DROP DISPENSING: 0,6ml.

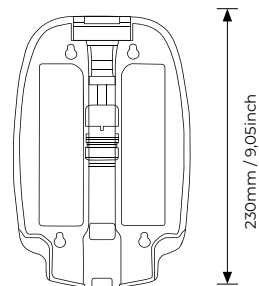
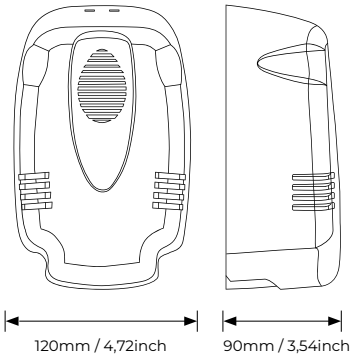

INSTRUCTIONS FOR USE

1. Open the unit by inserting the key into the lock and insert 2 LR20 ALKALINE batteries.
2. Take the cap off the refill. Place the refill inside the device. At the back plate of the Proanplus autosanitizer, introduce an evaporation strip by the upper opening, leading it through the guides until reaching the deposit with the chemical solution. Close the unit.
3. Turn on the equipment by selecting the "on" mode. Select the frequency mode (30 or 60 days). The LED's will light up when the unit is working properly.

PRECAUTIONS

- Install the unit in such a manner that it is at an optimal height to carry out its function.
- The unit can only be installed by trained personnel.
- Prior to switching on, check that there is not humidity or wet components near to any electric components.
- Never leave a dead battery inside the unit.
- Take the battery and refill out when not using the unit for a long period.
- Change the evaporation strip each time you change the refill.

Register No.: AN-04-DM-01
Version: 002
Date: 15 / 10 / 2021

AVAILABLE FRAGRANCES

- Tangerine Upper
- Tangerine
- Pine
- Proflower
- Red Fruits
- Just Washed
- Tropical
- Peach

BIOLOGICAL FORMULATION:

- ProanGreen
- ProanLip

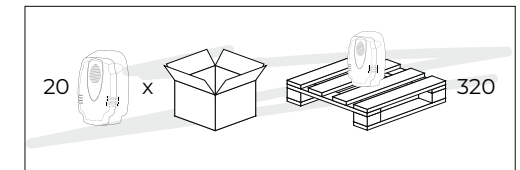

AUTOSANITIZERS ON PALLETS

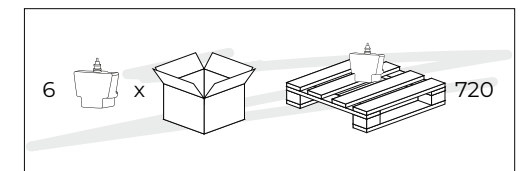

REFILL ON PALLETS