

DATA SHEET

REF. BP1, BP2

SHOWER SOAP DISPENSER



GENERAL

WARRANTY: 2 years.
HOW TO USE: Pressing the spare.

AMBIENCE

TEMPERATURE RANGE: 5 / 40°C.
HUMIDITY RANGE: 20-90%.

SHOWER SOAP DISPENSER

MOUNTING: Screwed to the wall or with adhesive tape.
NET WEIGHT SOAP BOTTLE: 326g.
NET WEIGHT SUPPORT: 80g.
SIZE: 64 x 75 x 145mm / 2.51 x 2.95 x 5.70inch.
MATERIAL: ABS plastic.
COLOR: Black.
SECURITY GUARANTEE: Integrated.
MARKETING: Can be customized with logo / label.

REFILL

MATERIAL: Polypropylene.
CAPACITY: 300ml.
AVAILABLE IN: Bottle.

AVAILABLE REFILLS (300ml)

BODY WASH AND SHAMPOO (300ml): Soft texture and a fresh green apple scent, for deep hygiene and cleansing of the skin and hair.

HYDROALCOHOLIC GEL (300ml): Eliminates 99,9% of bacteria on the hands. No need to rinse with water or dry with a towel or paper. Hydrates and softens the skin.

TOILET SEAT CLEANER (300ml): Eliminates germs and dirt from the toilet seat, acting as an effective barrier against pathogens and minimizing the risk of infections.

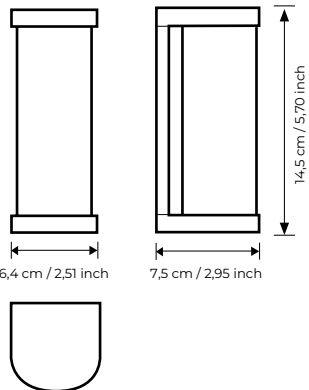

HOW TO USE

1. Fix the soap dispenser to the wall chosen by screws or with double-sided adhesive tape.
2. Open the soap holder support by inserting the key into the slot on the side and place the refill.
3. Remove the protective adhesive from the soap dispenser.
4. Place the soap bottle in the holder with the nozzle facing down and close the holder.

FEATURES

The product is marketed two in one, bath gel and shampoo. Simple and easy to recharge and clean (smooth surfaces). Practical size: Model suitable for communities. Easy installation, no need drill. Valid for any surface (marble, glass, tile, etc). Equipped with translucent strip to ensure the correct control of product consumption. Reinforced with integrated safety closure. Provided with an anti-drip valve that avoids wasting the product.

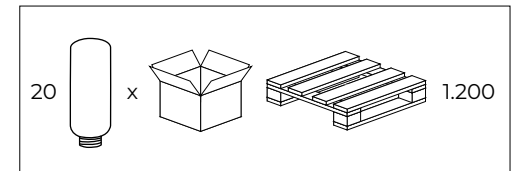

BOTTLES ON PALLETS

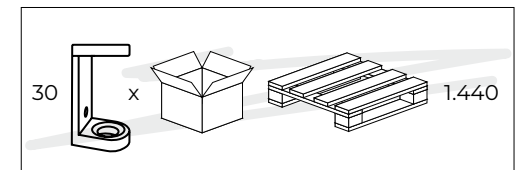

HOLDER ON PALLETS

Register No.: AN-04-DM-01
Version: 002
Date: 19 / 10 / 2021